

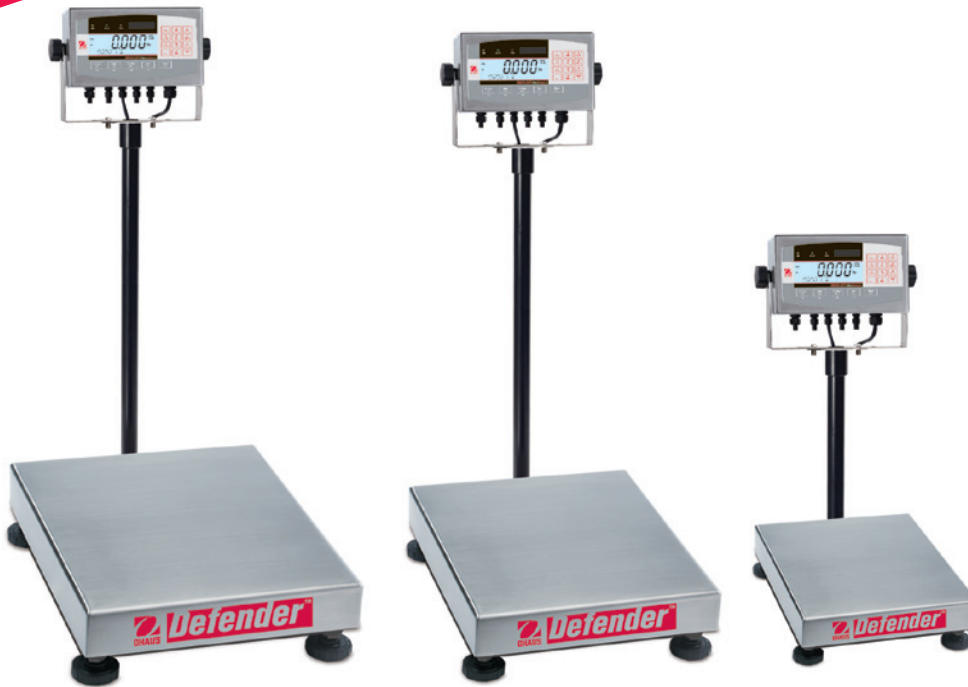

Defender™ 7000X

Advanced Xtreme Rectangular Scales



Counting function is not legal for trade

Advanced Smart Functionality, Durability, OHAUS Quality and Value

The OHAUS Defender™ 7000 Series is a feature-rich line of bench scales, combining a stainless steel D71XW indicator with a rectangular, painted steel base and a painted steel column. Ideal for shipping and receiving, production, packaging and general commercial and industrial weighing applications, the Defender 7000 offers a multifunctional indicator with multiple weighing units, alpha-numeric keypad and software modes to meet the requirements of industrial and lab applications. With rugged construction, comprehensive yet intuitive software and multiple connectivity options, the Defender 7000 can meet the needs of demanding industrial operations.

Standard Features Include:

- All steel construction with stainless steel indicator and painted steel column and base
- 5,000-7,500d default resolution
- Certified resolution up to 1:3,000
- Quick display of results using large dual line LCD with high-contrast white backlight
- Temporary display of 10x readability in weighing mode using quick key press
- Easy to operate with positive feedback 5-function key and alpha-numeric membrane keypad
- Weighs in one or more units: kg, g, lb, oz, lb:oz (decimal), tonnes and user-definable custom unit
- Multiple weighing modes including Counting, Percent Weighing, Dynamic/Animal Weighing, Checkweighing, Display Hold, and Accumulation
- 255 item Library data storage function
- Internal power supply with universal line cord or optional NiMH internal rechargeable power pack available
- Includes RS232 interface with GMP/GLP data output including date and time, and external analog base input for dual-base counting
- Base and indicator connected using quick connect plug
- Options include DC relay control kit, AC relay control kit, RS485/422 and 2nd RS232 interfaces, Alibi memory module

Defender™ 7000X Advanced Xtreme R

The Defender 7000 Offers Multiple Features and Easy Configuration:

To meet different operational needs, the Defender 7000 includes a suite of configurable software:

- Counting mode for packaging and inventory control, enabling counting into a container or out of a container for bulk operations. Supports a maximum counting resolution to 1:500,000 (minimum APW equal to 0.1d), selectable auto-optimization of average piece weight (APW). APW data can be displayed at any time using a quick key press.
- Percent Weighing mode for formulation and mixing applications, with display of reference weight with quick key press.
- Dynamic/Animal Weighing with selectable averaging times from 0-60 seconds.
- Checkweighing function for count and weight checking, with display of results using LCD display and red/yellow/green LEDs. Audible beeper can be configured to prompt when weight is within range, under, over, or under or over range. Target values can be displayed at any time using a quick key press.
- Display Hold mode for weighing large packages, holds last stable weight on display until cleared manually or automatically
- The Defender 7000 weighs in one or more user-selectable units: kg, g, lb, oz, lb:oz (decimal), tonnes and user-definable custom unit
- Supports GMP/GLP data output with date, time user ID, project ID and scale ID. The Defender 7000 features selectable print options for data and print format
- Software lockouts for menu items as well as individual key functions to limit operator access to functions
- Library storage for up to 255 memory records that may contain data from a combination of different modes. These reference data can be quickly and conveniently recalled for use with the active mode.
- Multi-language feature allows the user to display operation and menu text in the language of their choice: English, Spanish, French, German, Italian. This allows for convenience and ease of training and operation of the Defender 7000.
- Accumulation mode with statistics feature allows totalizing weight and count values manually or automatically. The total accumulated value is displayed in real-time. With the press of the "Info" key, the number of weighments, average, standard deviation, minimum, maximum and difference are displayed. These statistical values can also be printed.
- Dual scale connections are built-in for 2-scale counting configuration. Connect two bases, a higher resolution base to optimize average piece weight, in conjunction with a large capacity base to weigh/count in bulk.
- Store, view and print over 262,000 date and time-stamped weighing results with the optional Alibi memory kit

Outline Dimensions

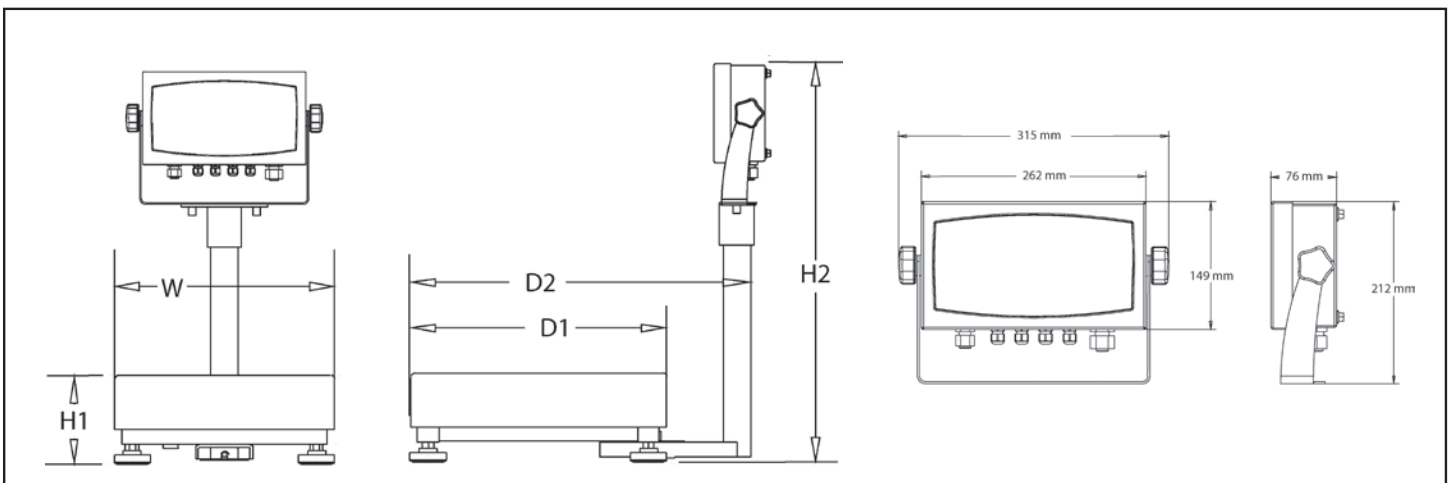

Rectangular Scales

Standard Features:

Optional NiMH Battery

Allows for use in environments where an electrical outlet may not be readily available

Internal Slot for Capacity Label

Protects label from the effects of moisture and external environments

Stainless Steel 304 NEMA 4X/IP66 Enclosure

Indoor/outdoor protection against falling dirt, rain, sleet, snow, windblown dust, splashing and corrosion



3-Color LED Checkweigh Indication

with configurable beeper alert

High-Visibility Dual Line LCD Display

with bright white LED backlight and fast display stable weight within 2 seconds

Included Table/Wall Mount Bracket

With large ergonomic adjustable knobs to maximize viewing angles.

Library Data Storage Function

Storage and quick recall of data records for up to 255 items

Hinged Front Cover

Only four sealing screws secure the housing for ease of servicing, while still ensuring IP66 seal integrity



One-Key, Multiple Mode Selection

Counting, Dynamic Weighing, Display Hold, Percent Weighing and Checkweighing

Stay Connected/Output

Built in RS232 bi-directional interface and built-in external input, optional RS422/485, optional second RS232 and optional AC or DC relay. Optional Alibi memory kit for data recording and traceability

Universal Switching Power Supply

Automatically adapts to different voltages and frequencies; plug anywhere, anytime

Durable Base Frame Construction

Stainless steel pans and painted steel form-and-weld frames (R, L bases) provide maximum durability, rigidity and structural integrity. Load-unload cycle tested to ensure long-term performance.



Painted Steel Columns

Available in both short and tall lengths

Fully Adjustable Feet

Four rugged, adjustable feet help prevent slippage on wet or uneven surfaces



Options and Accessories

Interface Options

	OHAUS Number
AC Relay Kit.....	80500720
DC Relay Kit.....	80500727
RS485/422 Interface Kit.....	80500731
Second RS232 Interface Kit.....	80500733
Foot Switch.....	71173378

Power Options

Rechargeable Battery Kit, T71P/T71XW.....	80500729
---	----------

Other Accessories

	OHAUS Number
Compact Dot Matrix Impact Printer.....	80252042
Compact Thermal Printer.....	80251992
OHAUS Collect Software.....	80500746
Alibi Memory Option Kit.....	80500503
TAL Software WinWedge.....	SW12W
Paper for Printer, 80252042 (1 roll).....	80251932
Ribbon for Printer, 80252042.....	80251933
RS232 Cable & Adapter, 80252042 Printer to T71XW.....	80252574
RS232 Cable, PC 9 Pin to T71XW.....	80500552
RS232 Cable, PC 25-pin to T71XW.....	80500553

Defender™ 7000X Rectangular Scales

Specifications

Model	D71XW15HR1	D71XW30HR1	D71XW60HR1	D71XW60HL2	D71XW100HL2	D71XW150HX2	D71XW300HX2
Capacity (max) x Default Readability (d)	30lb x 0.005lb 480oz x 0.1oz 30lb : 0.1oz 15kg x 0.002kg 15000g x 2g	60lb x 0.01lb 960oz x 0.2oz 60lb x 0.2oz 30kg x 0.005kg 30000g x 5g	150lb x 0.02lb 2400oz x 0.5oz 150lb : 0.5oz 60kg x 0.01kg 60000g x 10g	250lb x 0.05lb 4000oz x 1oz 250lb : 1oz 100kg x 0.02kg 100000g x 20g	300lb x 0.05lb 4800oz x 1oz 300lb : 1oz 150kg x 0.02kg 150000g x 20g	600lb x 0.1lb 9600oz x 2oz 600lb : 2oz 300kg x 0.05kg 300000g x 50g	
Maximum Displayed Resolution	1:7500	1:6000	1:7500	1:5000	1:7500	1:6000	
Capacity x Certified/Approved Readability	30 lb x 0.01 lb 15 kg x 0.005 kg	60 lb x 0.02 lb 30 kg x 0.01 kg	150 lb x 0.05 lb 60 kg x 0.02 kg	250 lb x 0.1 lb 100 kg x 0.05 kg	300 lb x 0.1 lb 150 kg x 0.05 kg	600 lb x 0.2 lb 300 kg x 0.1 kg	
Maximum Certified Resolution	1:3,000	1:3,000	1:3,000	1:2,500	1:3,000	1:3,000	
Indicator Model	T71XW						
Column	13.8 in / 350 mm painted steel			26.8 in / 680 mm painted steel			
Construction	Stainless steel indicator, removable weighing platform, painted steel column and base construction, aluminum loadcell						
Safe Overload Capacity	150% of maximum capacity						
Protection	NEMA 4X/IP66 for indicator, IP67 for loadcell						
Weighing Units	lb, oz, lb:oz, kg, g, custom unit						
Modes/Features	Static Weighing (single or dual range), Dynamic Weighing, Counting, Checkweighing, Percent Weighing, Display Hold, Accumulation, Library						
Display	6-digit, 7-segment LCD, 25mm/1 inch high primary digits, dual line, with high-contrast white LED backlight						
Keypad	Positive feedback membrane keys, 5 function keys and alpha-numeric keypad						
Stabilization Time	Within 2 seconds						
Auto-zero Tracking	Off, 0.5, 1 or 3 d						
Zeroing Range	2% or 100% of capacity						
Calibration	Span: 1kg or 1lb to 100% of capacity / Linearity: 3 or 5 point						
Power	100-240 VAC / 50-60Hz internal universal power supply						
Interface	RS232 and external input						
Operating Temperature Range	14°F to 104°F / -10°C to 40°C						
Scale Dimensions (W x H1 x H2 x D1 x D2)	12 x 3.7 x 23.6 x 14 x 18.7 in 305 x 95 x 600 x 355 x 475 mm		15.7 x 4.1 x 37 x 19.7 x 24.4 in 400 x 105 x 940 x 500 x 620 mm		16.5 x 4.9 x 37 x 21.7 x 26.4 in 420 x 125 x 940 x 550 x 670 mm		
Shipping Dimensions (L x W x H)	19.3 x 16.1 x 17.3 in 490 x 410 x 440 mm		29.1 x 27.2 x 9.1 in 740 x 690 x 230 mm		29.5 x 30 x 9.1 in 750 x 710 x 230 mm		
Approx. Net Weight	28.4 lb / 12.9 kg		52.2 lb / 23.7 kg		64.1 lb / 29.1 kg		
Approx. Shipping Weight	33.3 lb / 15.1 kg		59.5 lb / 27 kg		70.7 lb / 32.1 kg		

Features

T71XW: Stainless steel water resistant NEMA 4X / IP66 housing, integral faceplate supports for easy servicing, backlit LCD weight display, checkweighing indication (green, yellow, red), membrane keypad with raised tactile keys, built-in bi-directional RS232 with manual/continuous/interval printing, external tare input, hardware configuration lockout switch, internal switching power supply with hardwired cord.

Other Features

Zero point calibration, calibration test, span or linear calibration, selectable auto-zero tracking range, selectable stability range, selectable averaging level, selectable LCD backlight, selectable auto shutoff, retain zero weight data after power-off, Geo gravity adjustment, selectable key beep, key function lock, menu lock, selectable power-on and calibration unit, battery status display, display of gross/net weight, indication of stability, center of zero, over- and underweight, overload and underload conditions. Configuration menus for PRINT1, PRINT2, COM1, COM2, and I/O.

Compliance

- **Legal for Trade (Made from Certified/Approved weighing components):** NTEP (CC No. 09-102 for indicator; 99-203A3 for bases) / Measurement Canada (Approval No. AM-5762 for Indicator; AM-5675 for bases)
- **Safety and EMC:** UL_{us} 2005/95/EC low voltage directive: EN60950-1:2001, FCC Part 15 Class A 2004/108/EC EMC directive: EN61326-1:1997; +A1:1998; +A2:2001; + A3>2003
- **Other:** Compliant to Directive 2002/96/EC on waste electrical and electronic equipment (WEEE)
- **Quality:** OHAUS quality management system registered to ISO 9001:2008

OHAUS CORPORATION

* 7 Campus Drive
Suite 310
Parsippany, NJ 07054 USA

Tel: 800.672.7722
973.377.9000
Fax: 973.944.7177

www.ohaus.com

*With offices throughout Europe,
Asia, and Latin America*

* **ISO 9001**
Registered Quality Management System

