

EGT-1

BSL

Materials: Tool steel
Material: acero

SPECIAL LOAD CELL FOR CRANE SCALE

CELDA DE CARGA ESPECIAL PARA BALANZA GRUA

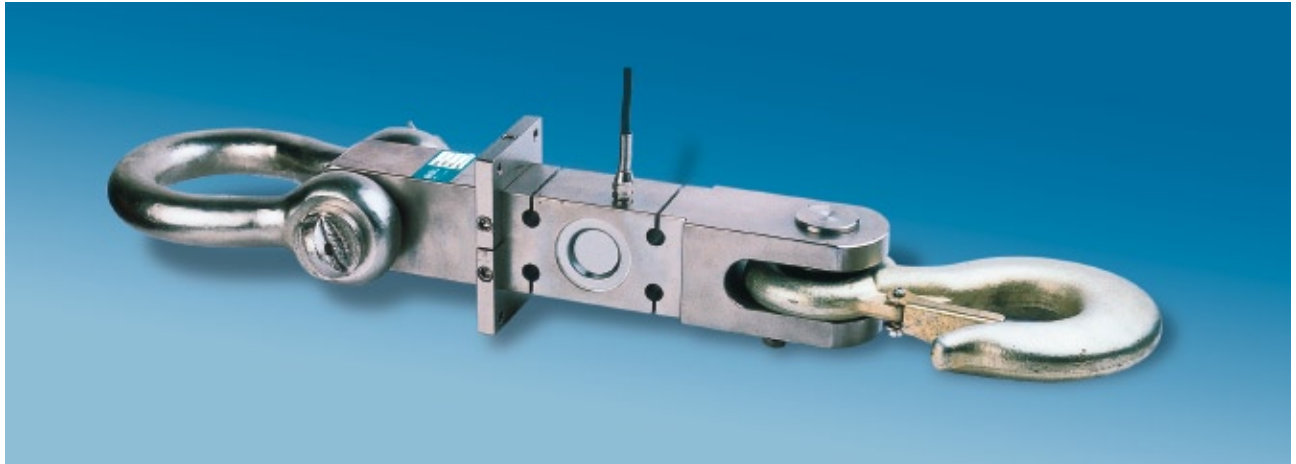

Datos técnicos grales.	Main technical data	Unit	Technical quota
Sensibilidad	Sensitivity	m V/V	1.5±0.01
Alinealidad	Nonlinearity	% FS	± 0.02
Histeresis	Hysteresis		
Repetibilidad	Repeatability	% FS	0.01
Creep	Creep	% FS/30min	± 0.02
Balance de cero	Zero balance	% FS	± 1
Coefficiente temp. en cero	Zero temperature coefficient	% FS / 10°C	± 0.02
Coefficiente temp. en carga	Rated output temperature coefficient	% FS / 10°C	
Resistencia de entrada	Input resistance	Ω	765 ± 15
Resistencia de salida	Output resistance	Ω	700 ± 5
Resistencia de aislación	Insulation resistance	M Ω	≥ 5000
Tensión excitación	Supply Voltage	V	10 (DC / AC) MAX: 15 (DC / AC)
Rango compensado de temp.	Temperature compensation range	°C	-10~+50
Temperatura límite	Safe temperature range	°C	-20~+60
Seguridad de sobrecarga	Safe overload	% FS	300
Cable de conexión	Connect cable	mm	Ø4 x 500 (1000)
Método de conexión	Method of connecting wire	input: Red (+) Black (-) Output Green (+) White (-)	

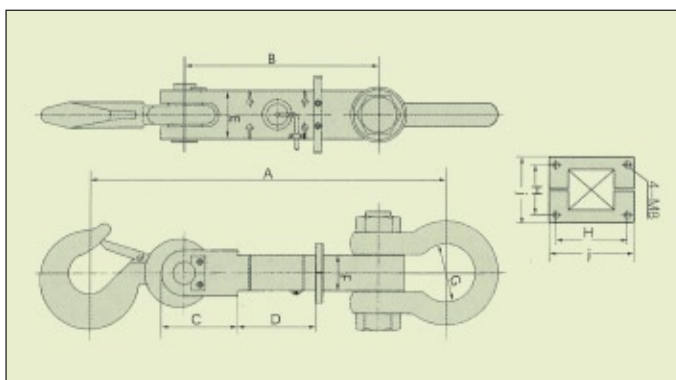

		Medidas / Size: mm							
Capacidad: Rated load: t	A	B	C	D	E	F	G	H	J
1 - 3	440	260	98	110	56	43	75	60 x 70	74 x 84
5	550	303	118	120	68	54	90	65 x 90	82 x 110
10	590	325	133	130	80	60	98	76 x 110	100 x 130
20	758	354	158	148	98	70	150	80 x 130	110 x 160