

MTS-3

BSL

Materials: Tool steel
Material: acero

"S" TYPE LOAD CELL

CELDA DE CARGA A LA TENSION TIPO S



Datos técnicos grales.	Main technical data	Unit	Technical quota
Sensibilidad	Sensitivity	m V/V	1.5±0.025
Alinealidad	Nonlinearity	% FS	± 0.05
Histeresis	Hysteresis		
Repetibilidad	Repeatability	% FS	0.03
Creep	Creep	% FS/30min	± 0.05
Balance de cero	Zero balance	% FS	± 1
Coeficiente temp. en cero	Zero temperature coefficient	% FS / 10°C	± 0.05
Coeficiente temp. en carga	Rated output temperature coefficient	% FS / 10°C	
Resistencia de entrada	Input resistance	Ω	385 ± 10
Resistencia de salida	Output resistance	Ω	350 ± 3
Resistencia de aislación	Insulation resistance	M Ω	≥ 2000
Tensión excitación	Supply Voltage	V	10 (DC / AC) MAX: 15 (DC / AC)
Rango compensado de temp.	Temperature compensation range	°C	-10~+50
Temperatura límite	Safe temperature range	°C	-20~+60
Seguridad de sobrecarga	Safe overload	% FS	120
Cable de conexión	Connect cable	mm	Ø5 x 3000 (5000)
Método de conexión	Method of connecting wire	input: Red (+) Black (-) Output Green (+) White (-)	

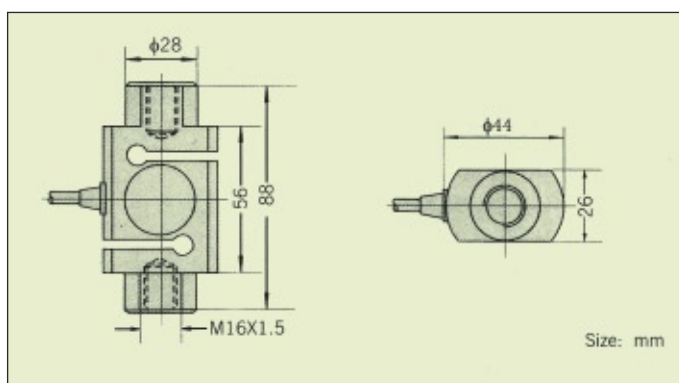

CAPACIDAD / RATED LOAD:
100, 200, 300, 500
700, 1000 kg